



J50 JAW CRUSHER

McCloskey International has a proven reputation for designing quality, best-in-class equipment and the J50 Crusher brings even more power and productivity together in one machine. With its class-leading throughput and capacity and the largest stockpile height in its category the J50 crusher continues to push the boundaries of industry performance.

FEATURES

- ✓ 1270 (50") x 735 (29") single toggle jaw
- ✓ Hydraulic CSS (Closed Side Setting) Adjust
- ✓ Integrated hydraulic folding hopper
- ✓ Integrated hydraulic folding stockpiling conveyors
- ✓ 1200mm (48") main conveyor
- ✓ Large gap between crusher discharge and main conveyor feedboot
- ✓ Open chassis design for ease of maintenance
- ✓ Fast setup time



With 1270mm (50") x 735mm (29") single toggle jaw (the widest jaw in its class), the J50 places McCloskey International at the fore of portable crushing machinery.

Maximum productivity is delivered through the enhancements to the jaw box including heavier flywheels and optimization for all crushing applications. The J50's jaw speed leads to better reduction and material being processed faster through the crushing chamber.

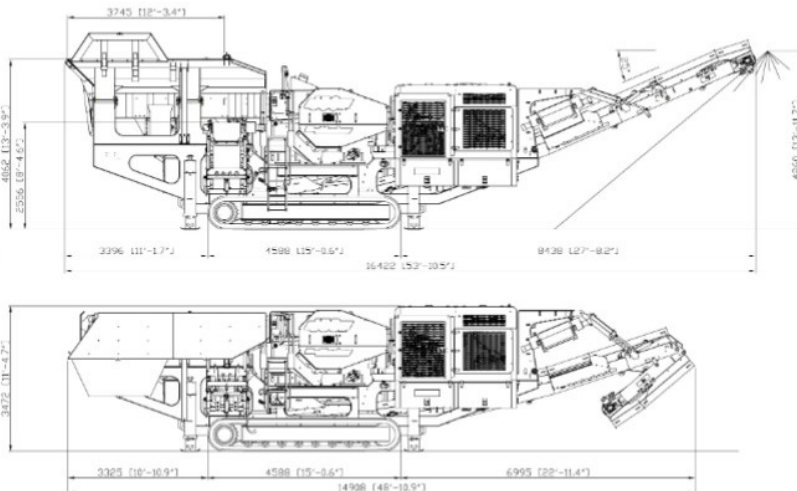

J50 TECH SPECS

Engine	280 kW (375 Hp)
Feed Opening	1270mm (50") x 735mm (29")
Grizzly Feeder	
Width*	1164mm (45.8")
Length	4450mm (175")
Hopper Volume	6.3m ³ (8.2yd ³)
Stockpile Height	
Main Conveyor	4250mm (13' 11")
Side Conveyor	2584mm (8' 6")

TRANSPORT

Height	3.40m (11' 1.8")
Length	14.48m (47' 5.9")
Width	2.5m (8' 2.5")
Weight - w/ magnet & side conveyor	59,000kg (130,702 lb)

OPTIONS

Main Conveyor Variable Speed | 50mm or 70mm Aperture Bofor | Hopper Extensions | Overband Magnet | Water Pump and Dust Suppression System | Refueling Pump | Square Tooth Quarry Jaws | 30mm Corrugated Jaws | 50 mm Corrugated Jaws | Multi-tooth Dies | Crusher Deflector Plate

*Inside wearplates